

1

2

3

4

5

6

NOTES:

- 1. DB-1001-A: DESIGN, PERFORM, INTERFACE, AND QUALIFICATION REQUIREMENTS.
- 2. MAX. WEIGHT: 19 GRAMS
- 3. PART MARKING:
DB-0406L
OSCJ7
YYWW



SOCKET CONTACT

DETAIL "A"

REVISIONS			
REV.	DESCRIPTION	DATE	APPROVED
A	Initial Release	12/06/10	D.D.

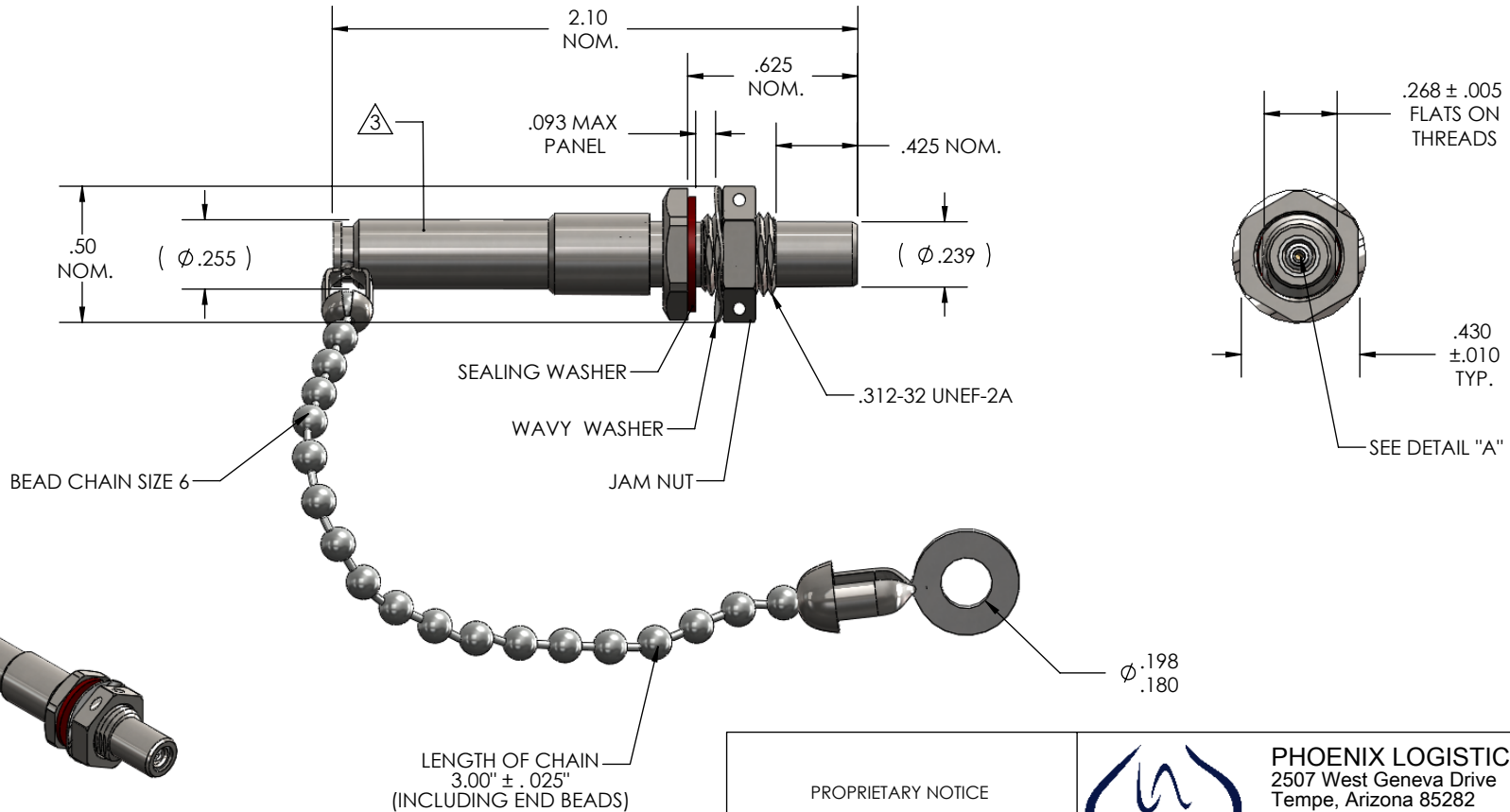

LENGTH OF CHAIN
3.00" ± .025"
(INCLUDING END BEADS)

PROPRIETARY NOTICE

THE INFORMATION HEREON/HEREIN IS PROPRIETARY TO PHOENIX LOGISTICS, INC. IT SHALL NOT BE COPIED, DISCLOSED OR USED (PARTIALLY OR WHOLLY) IN ANY MANNER WITHOUT PRIOR EXPRESSED WRITTEN AUTHORIZATION OF PHOENIX LOGISTICS, INC. RETURN TO PHOENIX LOGISTICS, INC.

DRAWN	M. MANGAN	12/06/10
CHECKED	J. MAZENAUER	12/06/10
APPROVED	D. DONG	12/06/10



PHOENIX LOGISTICS, INC.
2507 West Geneva Drive
Tempe, Arizona 85282
Tel: 602-231-8616 Fax: 602-273-9135
sales@phxlogistics.com
http://www.phxlogistics.com

TITLE: Terminator, W/ Configuration - Jack, (.093 max panel), Threaded, Socket, 78 Ω, Lanyard	
FSCM NO. OSCJ7	PART NUMBER DB-0406L