

NOTES:

- DC-1001-A: DESIGN, PERFORM, AND QUALIFICATION REQUIREMENTS.
- MAXIMUM WEIGHT EXCLUDING CABLES: 60 GRAMS.
- COUPLER IDENTIFICATION:
 MANUFACTURER NAME
 PART NUMBER
 CAGE CODE, DATE CODE
 SERIAL NUMBER

REVISIONS			
REV.	DESCRIPTION	DATE	APPROVED
A	Initial Release	01/14/11	D.D.

THREE STUB COUPLER SCHEMATIC

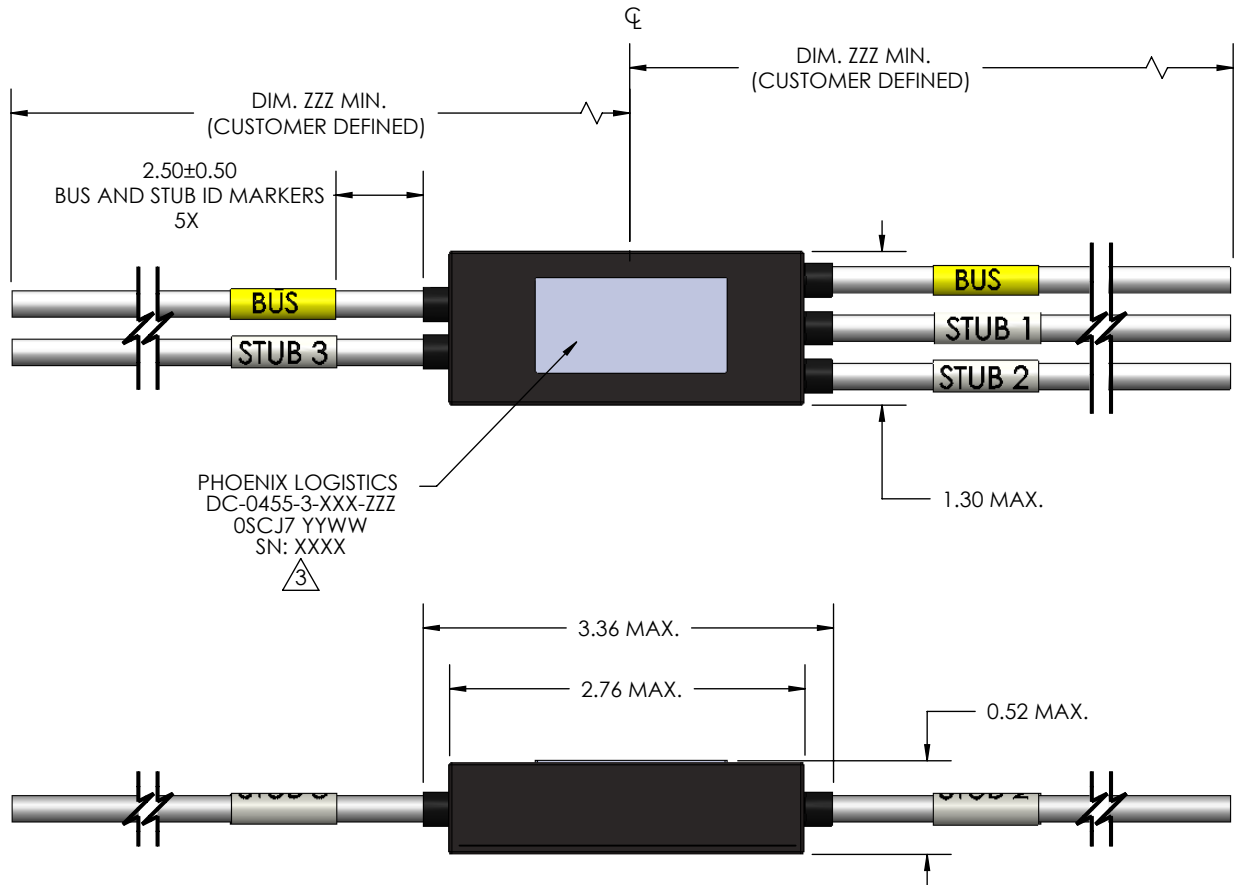
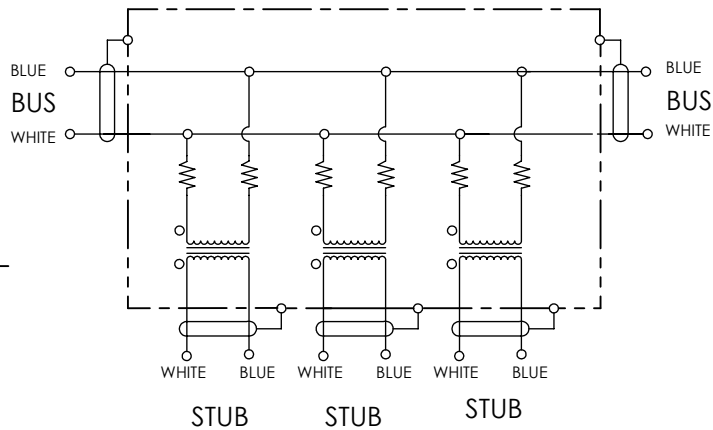

DC-0455-3-XXX-ZZZ

Schematic --- LENGTH OF CABLE IN INCHES

3 = Triple Stub

CABLE:
 612 = C24612 (Single Shielded)
 613 = C24613 (Double Shielded)
 614 = C24614 (EMP Hardened)
 176 = M17/176-00002
 CDC= Customer Defined Cable

PROPRIETARY NOTICE
 THE INFORMATION HEREON/HEREIN IS PROPRIETARY TO PHOENIX LOGISTICS, INC. IT SHALL NOT BE COPIED, DISCLOSED OR USED (PARTIALLY OR WHOLLY) IN ANY MANNER WITHOUT PRIOR EXPRESSED WRITTEN AUTHORIZATION OF PHOENIX LOGISTICS, INC. RETURN TO PHOENIX LOGISTICS, INC.



PHOENIX LOGISTICS, INC.
 2507 West Geneva Drive
 Tempe, Arizona 85282
 Tel: 602-231-8616 Fax: 602-273-9135

sales@phxlogistics.com
 http://www.phxlogistics.com

DRAWN	MARYLEN MANGAN	01/14/11
CHECKED	JoAN MAZENAUER	01/14/11
APPROVED	DANNY DONG	01/14/11

TITLE:	Coupler, In-Line, No Eyelet, Standard Schematic, 3 Stub	
FSCM NO.	OSCJ7	PART NUMBER
		DC-0455-3-XXX-ZZZ