

REVISIONS			
REV.	DESCRIPTION	DATE	APPROVED
A	ECO 790 - Release		

NOTES:

1. DB-1001A: DESIGN, PERFORM, INTERFACE, AND QUALIFICATION REQUIREMENTS.
2. MAX. WEIGHT: 7.5 GRAMS

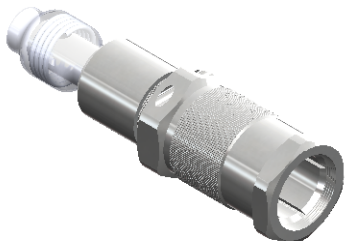
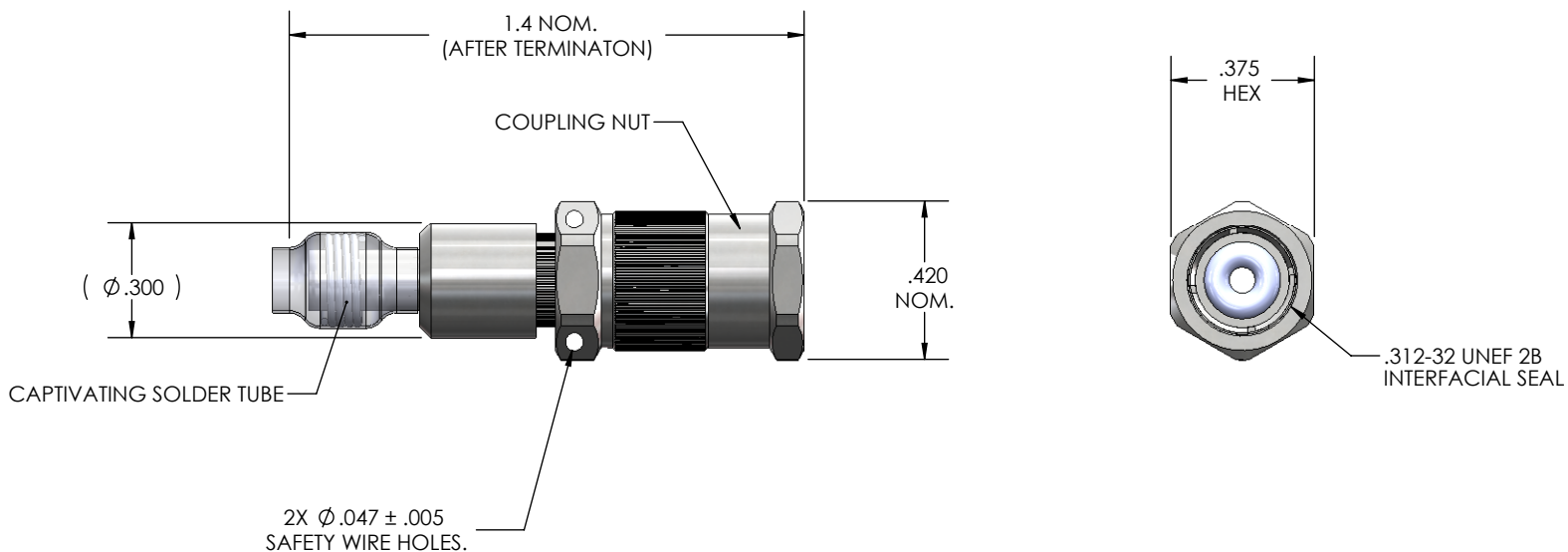

<b>PROPRIETARY NOTICE</b>		
THE INFORMATION HEREON/HEREIN IS PROPRIETARY TO PHOENIX LOGISTICS, INC. IT SHALL NOT BE COPIED, DISCLOSED OR USED (PARTIALLY OR WHOLLY) IN ANY MANNER WITHOUT PRIOR EXPRESSED WRITTEN AUTHORIZATION OF PHOENIX LOGISTICS, INC. RETURN TO PHOENIX LOGISTICS, INC.		
DRAWN	M. MANGAN	03/05/10
CHECKED		
APPROVED		

	<b>PHOENIX LOGISTICS, INC.</b> 2507 West Geneva Drive Tempe, Arizona 85282 Tel: 602-231-8616 Fax: 602-273-9135 sales@phxlogistics.com http://www.phxlogistics.com	
	TITLE: <b>Connector, Triaxial, Plug, No Contact</b>	
FSCM NO	OSCJ7	PART NUMBER
		DB-0411